

THIS DRAWING IS UNPUBLISHED. RELEASED FOR PUBLICATION
 © COPYRIGHT - By - ALL RIGHTS RESERVED.

Loc		DIST		REVISIONS			
P	LTR	DESCRIPTION	DATE	DWN	APVD		
	AL2	REVISED PER ECO-11-004820	11MAR11	RK	HMR		

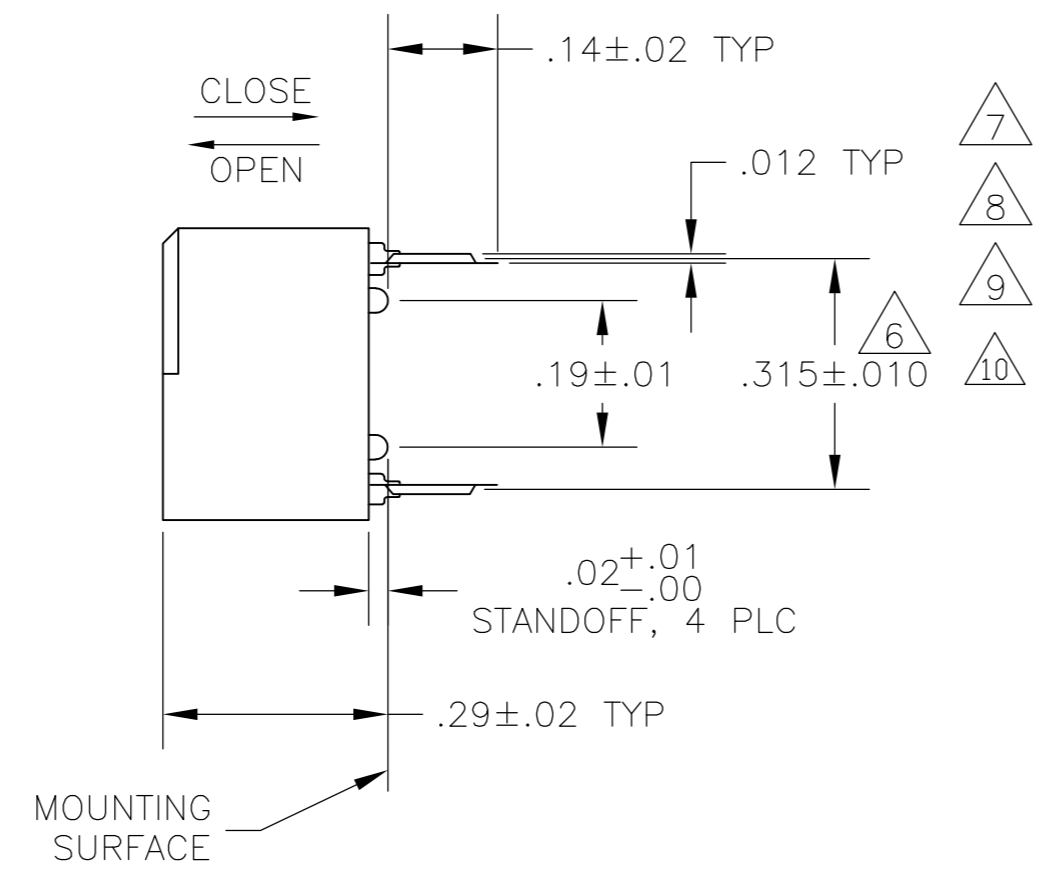
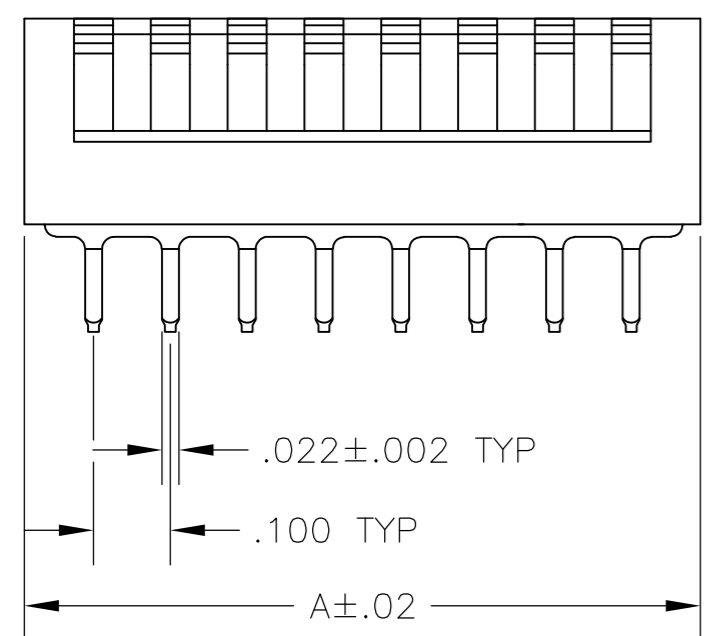
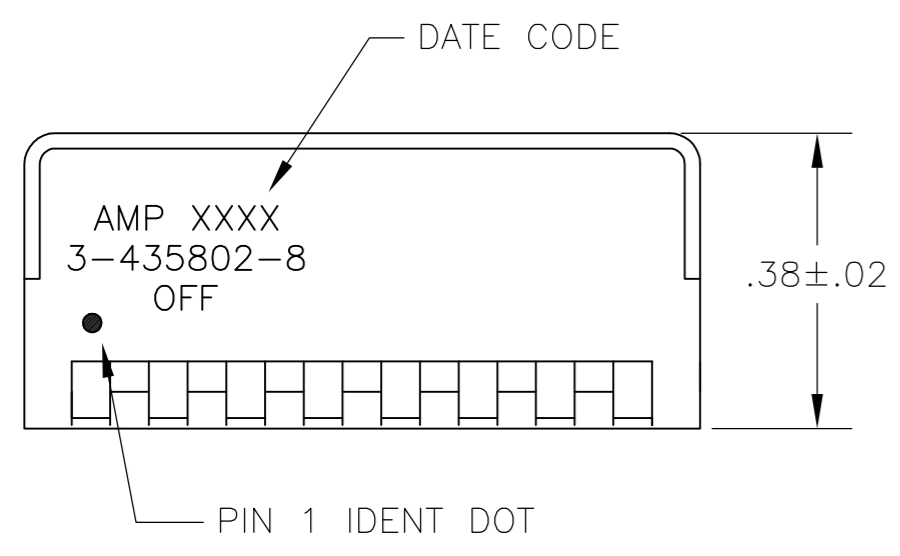
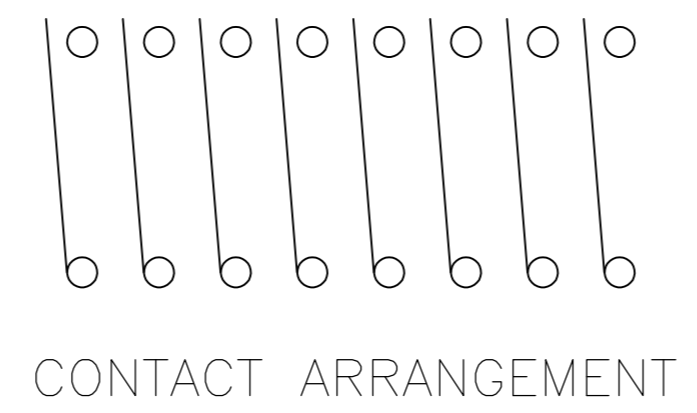

FIG 1



- 7 NO POSITION MARKING.
- 8 NO PART NO. MARKING.
- 9 STRIPPABLE TAPE SEAL, SEE FIGURE 8.
- 10 OBSOLETE PARTS: OBSOLETE CIS STREAMLINING PER D.RENAUD/D.SINISI

- 1 FOR ADDITIONAL SPECIFICATIONS SEE AMP PRODUCT SPEC 108-7519.
- 2 SWITCH SHOWN IN OPEN POSITION.
- 3 ALL CHARACTERS AND ROCKERS ARE WHITE, HOUSING IS BLACK.
- 4 STAMPING WILL VARY ON 2 AND 3 POSITION TOPS DUE TO SPACE RESTRICTIONS.
- 5 STRIPPABLE TRANSPARENT SEAL, SEE FIG 6.
- 6 .315 DIMENSION APPLIES AT TERMINAL TIPS. TERMINALS ARE .300^{+.010}_{-.000} AT MOUNTING SURFACE.

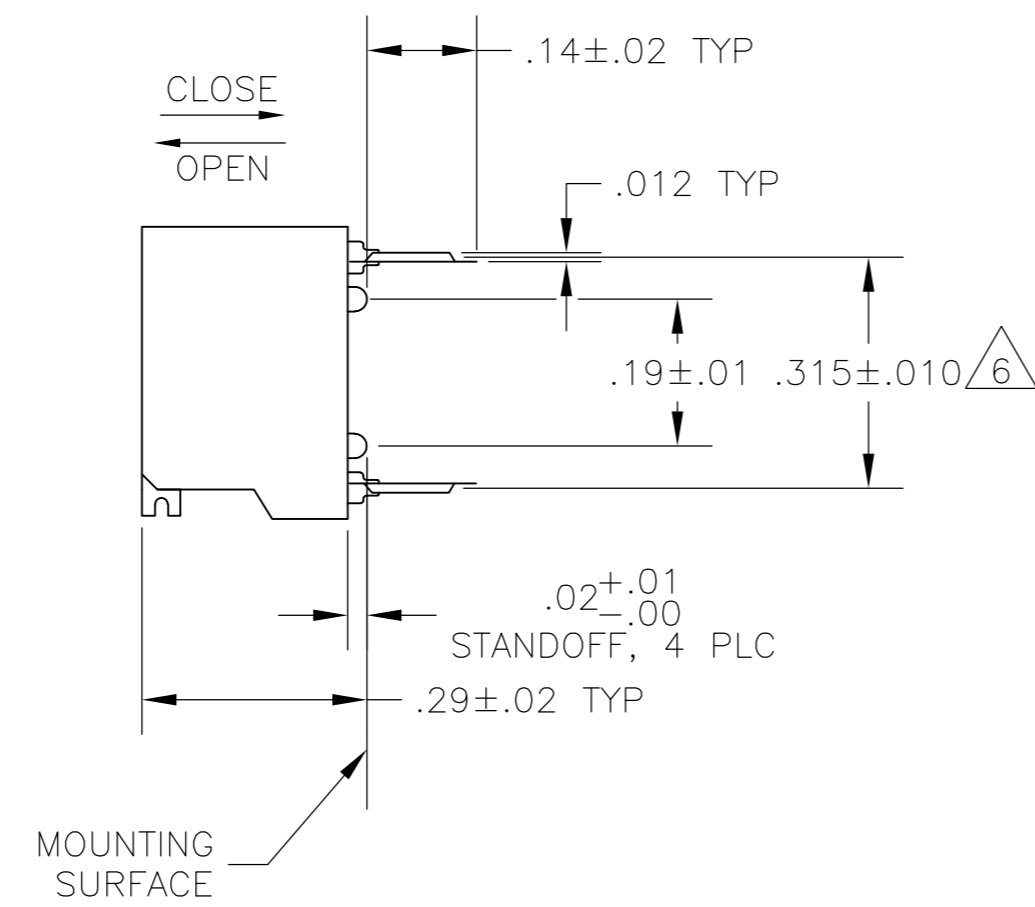
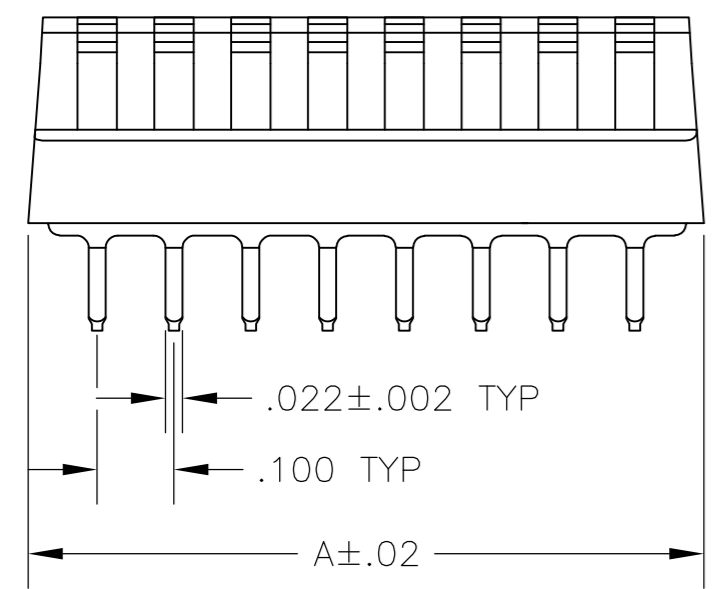
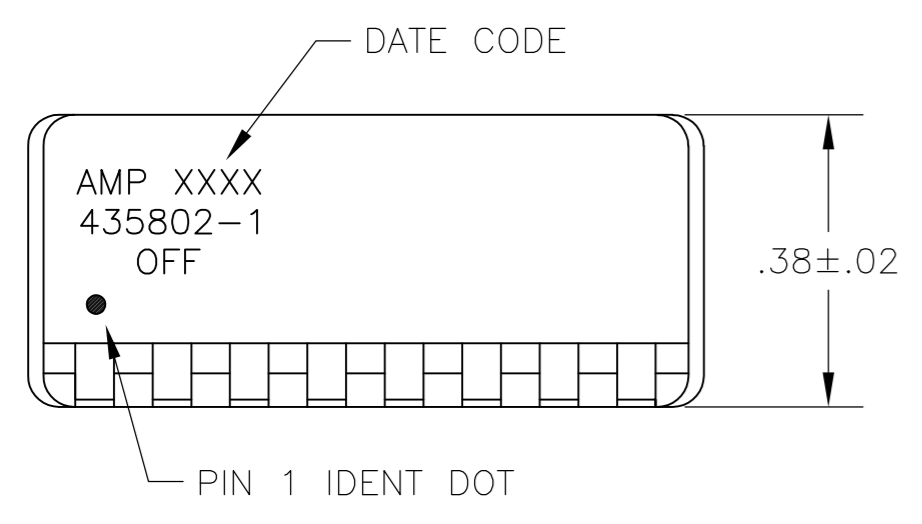

FIG 2

	FIG 2	FIG 3A& 7				
	FIG 1	FIG 3B	9	.88	8	3-435802-8
SUPSD BY 1-435802-6	FIG 2	7 8	5	.58	5	3-435802-1
10 OBSOLETE	FIG 2	7 8	5	.88	8	3-435802-0
SUPSD BY 2-5435802-9	FIG 2	7 8	5	.48	4	2-435802-9
SUPSD BY 1-435802-0	FIG 1	7	5	.28	2	2-435802-8
OBSOLETE	FIG 1	7	5	.28	2	2-435802-7
OBSOLETE	FIG 2	7	5	1.08	10	2-435802-6
OBSOLETE	FIG 2	FIG 4		.88	8	2-435802-5
OBSOLETE	FIG 2	7	5	.88	8	2-435802-4
OBSOLETE	FIG 2	FIG 3A& 5		.48	4	2-435802-3
	FIG 2			1.28	12	2-435802-2
	FIG 2			1.18	11	2-435802-1
	FIG 2			1.08	10	2-435802-0
	FIG 2	FIG 3A	5	.98	9	1-435802-9
	FIG 2			.78	7	1-435802-8
	FIG 2			.68	6	1-435802-7
	FIG 2			.58	5	1-435802-6
	FIG 2			.48	4	1-435802-5
	FIG 2			.38	3	1-435802-4
SUPSD BY 435802-2	FIG 2		5	.28	2	1-435802-3
SUPSD BY 3-1437590-2	FIG 1	FIG 3B		1.28	12	1-435802-2
10 OBSOLETE	FIG 2			.28	2	1-435802-0
	FIG 2	FIG 3B	5	.88	8	435802-9
	FIG 2			1.08	10	435802-8
10 SUPSD BY 5435802-7	FIG 2	FIG 3A		.98	9	435802-7
	FIG 2			.78	7	435802-6
	FIG 2			.68	6	435802-5
	FIG 2			.58	5	435802-4
	FIG 2			.48	4	435802-3
	FIG 2	FIG 3A		.38	3	435802-2
	FIG 2	FIG 3A		.88	8	435802-1
	HOUSING	MARKING	PROTECTIVE SEAL	A	NO OF POSN	PART NO.

435802-1 SHOWN

THIS DRAWING IS A CONTROLLED DOCUMENT.

DIMENSIONS: INCHES	TOLERANCES UNLESS OTHERWISE SPECIFIED:	DWN R. TALLEY 9-19-89	
		CHK R. MILLER 9-19-89	
		APVD H. LEITER 9-19-89	
		PRODUCT SPEC	NAME
		APPLICATION SPEC	SWITCH ASSY, DIP, TYPE C, 7000 SERIES, SPST, SIDE ACTUATED
MATERIAL HOUSING & ROCKERS: POLYESTER CONTACTS: BERYLLIUM COPPER	FINISH CONTACTS: PLATED .000030 MIN GOLD IN CONTACT AREA OVER .000050 MIN NICKEL	WEIGHT	SIZE A2 CAGE CODE 00779 DRAWING NO C=435802 RESTRICTED TO
		CUSTOMER DRAWING	SCALE 4:1 SHEET 1 OF 2 REV AL2

THIS DRAWING IS UNPUBLISHED. RELEASED FOR PUBLICATION
 © COPYRIGHT - By - ALL RIGHTS RESERVED.

LOC	DIST	REVISIONS			
P	LTR	DESCRIPTION	DATE	DWN	APVD
AD	00	SEE SHEET 1	-	-	-

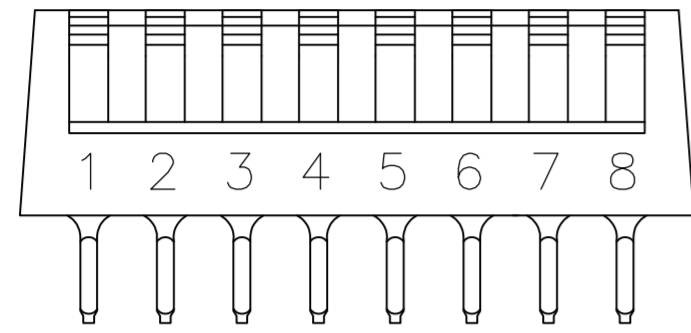

FIG 3A

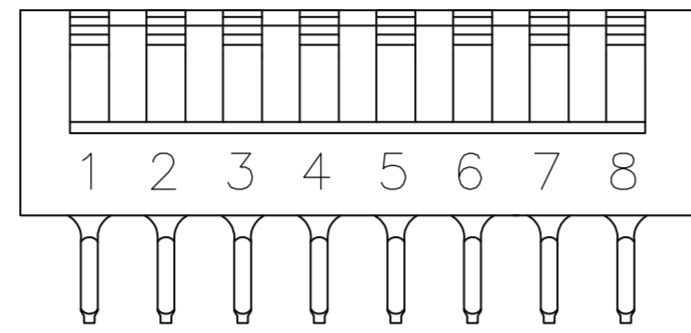

FIG 3B

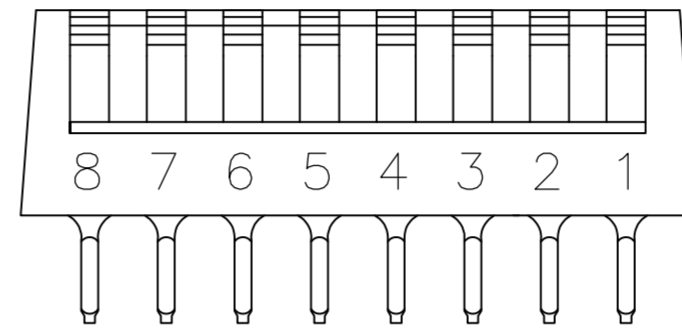

FIG 4

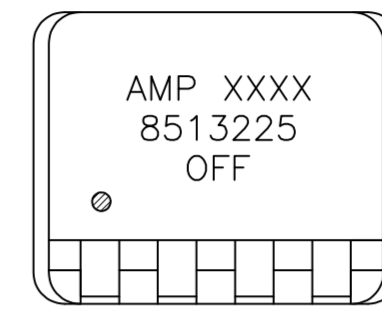
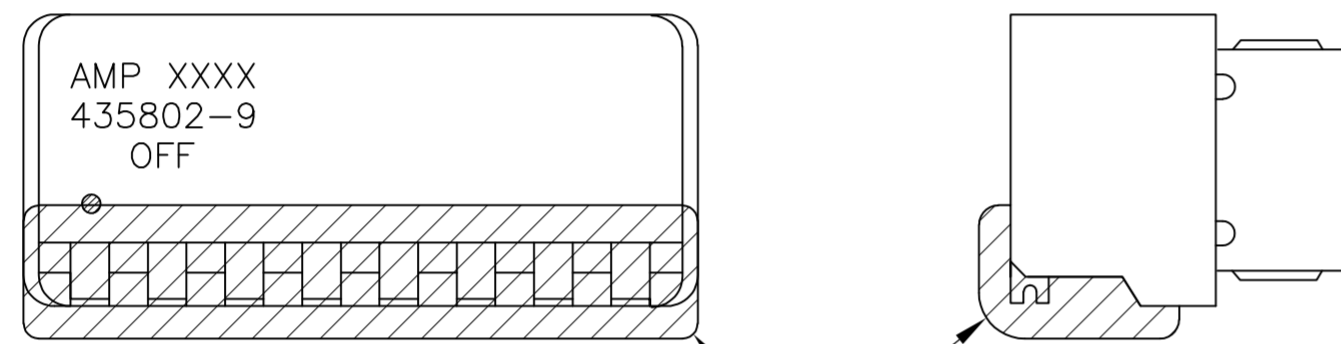
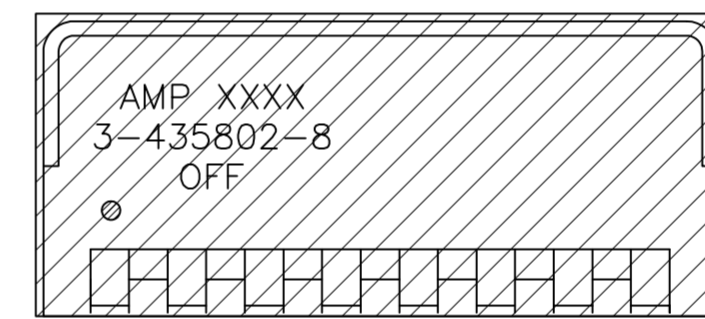

FIG 5



PROTECTIVE SEAL
FIG 6



PROTECTIVE SEAL

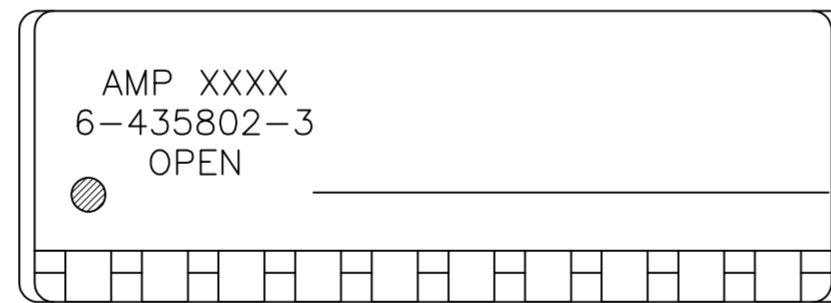

FIG 7

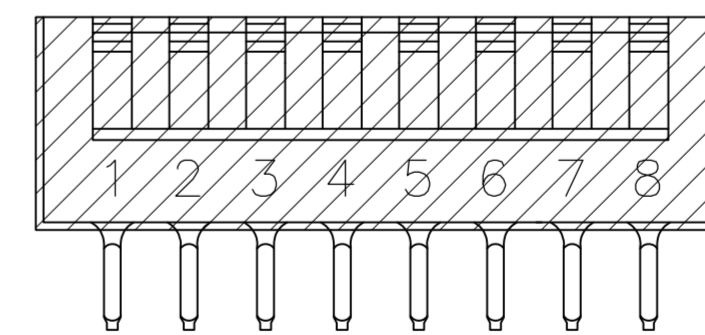

FIG 8

THIS DRAWING IS A CONTROLLED DOCUMENT.		DWN R. TALLEY 9-19-89	TE Connectivity																			
DIMENSIONS: INCHES		CHK R. MILLER 9-19-89																				
TOLERANCES UNLESS OTHERWISE SPECIFIED:		APVD H. LEITER 9-19-89	NAME SWITCH ASSY, DIP, TYPE C, 7000 SERIES, SPST, SIDE ACTUATED																			
<table border="1"> <tr><td>0 PLC</td><td>±</td><td>-</td></tr> <tr><td>1 PLC</td><td>±</td><td>-</td></tr> <tr><td>2 PLC</td><td>±</td><td>-</td></tr> <tr><td>3 PLC</td><td>±</td><td>.005</td></tr> <tr><td>4 PLC</td><td>±</td><td>-</td></tr> <tr><td>ANGLES</td><td>±</td><td>-</td></tr> </table>		0 PLC	±	-	1 PLC	±	-	2 PLC	±	-	3 PLC	±	.005	4 PLC	±	-	ANGLES	±	-	PRODUCT SPEC	SIZE A2	CAGE CODE 00779
0 PLC	±	-																				
1 PLC	±	-																				
2 PLC	±	-																				
3 PLC	±	.005																				
4 PLC	±	-																				
ANGLES	±	-																				
MATERIAL SEE SHEET 1		FINISH SEE SHEET 1	DRAWING NO C=435802	RESTRICTED TO -																		
		WEIGHT -	SCALE 4:1																			
		CUSTOMER DRAWING		SHEET 2 OF 2																		
				REV AL2																		